

NEW

OPTIMA

Horizontal moulders

- ✓ Horizontal moulding to take maximum care of the dough
- ✓ Strong pace
- ✓ Large production volumes
- ✓ Silent (-65dB)
- ✓ Stainless steel



Up to 1800 pieces an hour

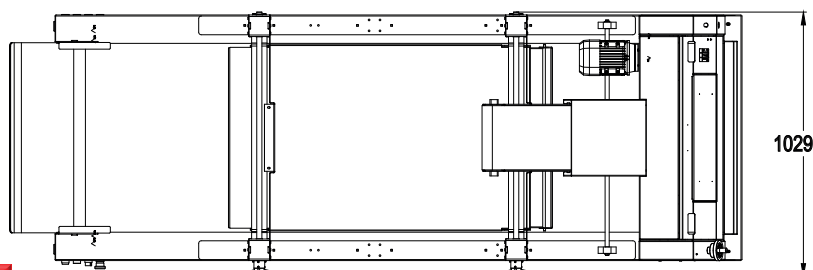
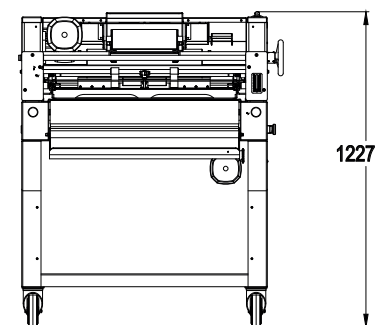
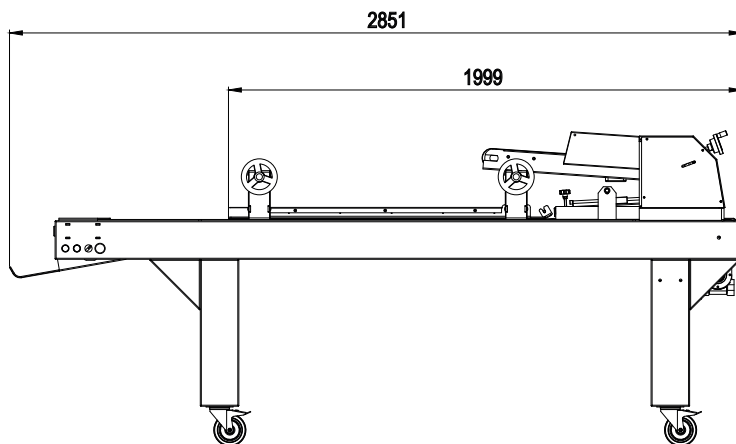



Easy-to-maintain scrapers



Two food-grade polyethylene rollers



Ergonomic, accurate indicators

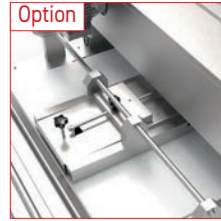

Option

Formmaster
Calibrator

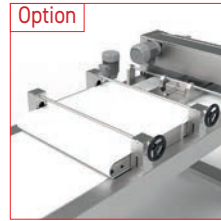

Option

Rollmaster
Motorised
elongation belt

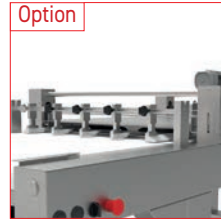

Option

Divimaster
4 small pieces cutters
Only available with **Formmaster** and
Rollmaster

OPTIMA

FEATURES

Min/max weight of dough pieces in grams	50/1300
Two food-grade PETP rolling rollers	•
Maximum speed in pieces per hour	1800
Power supply	400V three-phase
Motor power in kW	0,8
Belt type	Wooltop
Net weight in kg	310

CHOICES

Left / right controls	on request
-----------------------	------------

OPTIONS

Formmaster	•
Rollmaster	•
Divimaster	•
Feed belt	•

FEATURES

	OPTIMA + Formmaster	OPTIMA + Rollmaster	OPTIMA + Formmaster + Rollmaster	OPTIMA + Formmaster + Rollmaster + Divimaster
Min/max weight of dough pieces in grams	50/1300	50/1300	50/600	300/600
Two food-grade PETP rolling rollers	•	•	•	•
Maximum speed in pieces per hour	1800	1200	1200	4800
Motor power in kW	0,8	1	1 (2x0,37 + 0,18)	1 (2x0,37 + 0,18)
Net weight in kg	310	320	328	333