

PICO

- ✓ Minimum space requirement
- ✓ Can be used on a counter-top or on a base.
- ✓ Progressive traction lever for optimum effort control
- ✓ Front-loading for ergonomic efficiency

Up to 200 loaves an hour

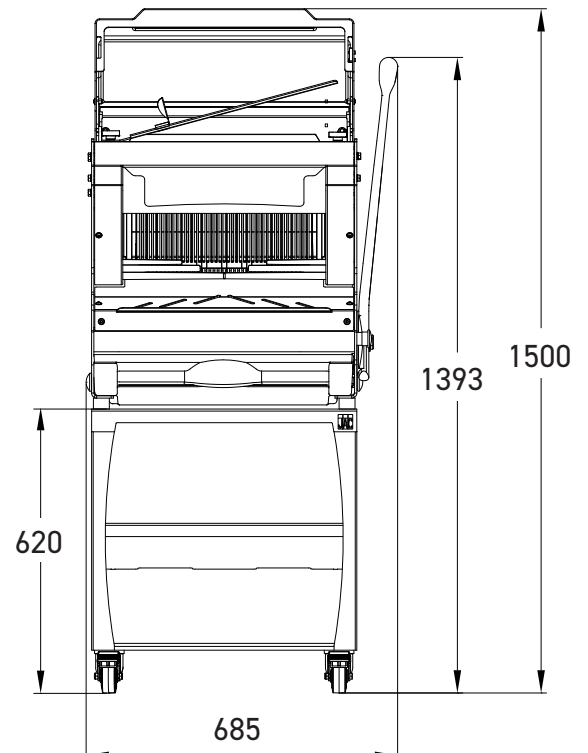

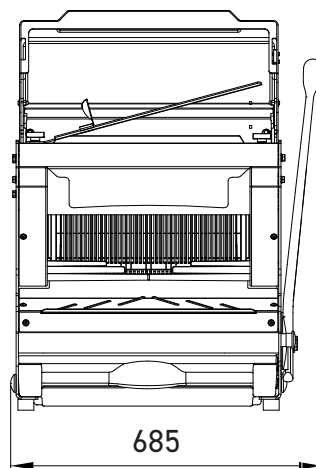
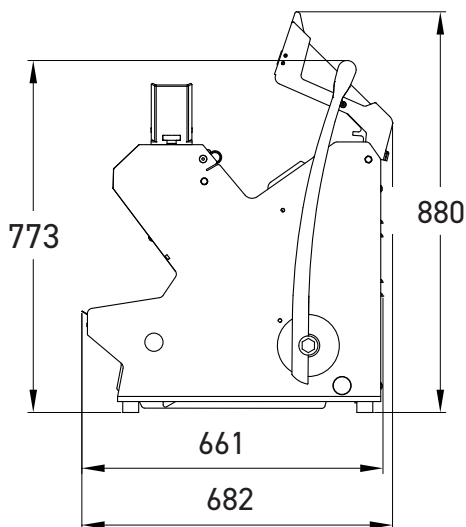

Progressive traction lever
Provides better control of effort.



Removable crumb collector
Made of light-weight material, accessible from the front. 7 litre capacity.



JAC FLAPS
Holds the loaf together for easier handling at the exit of the slicer.



Option
Jacfix
Holds the loaf together for easier handling at the exit of the slicer.



Option
Rear safety cover
Lever actuated, it closes at the start of the cut.



Option
Front safety cover
If opened during the cutting cycle, the machine stops.





Accessory
Wheeled base with two locking casters.
Provides storage space and mobility.



Type available
"M" system
Micronised blade lubrication system for cutting bread with a high rye content or sticky crumb. Developed by JAC, it consumes the least possible amount of oil (120 ml per 1000 loaves) and delivers consistent cutting quality.

FEATURES	PICO 450	PICO 450M 
Max. loaf dimensions in cm (L x W x H) without cover	44 x 30 x 18	44 x 29 x 18
Max. loaf dimensions in cm (L x W x H) with cover	44 x 26 x 16	44 x 26 x 16
Motor power in kW	0.49	1.5
Net weight (in kg)	105	115
Blade type and dimensions in mm	13 x 0.5 steel	13 x 0.5 Teflon coated

CHOICES	PICO 450	PICO 450M 
Slice thickness in mm	9 - 18	9 - 12
Loaf pusher height	Extra low (50mm) Low (80mm) High (100mm)	Misch (80mm)
Power supply	230V single phase 230V three-phase 400V three-phase	400V three-phase
Standard colour*	•	•

OPTIONS	PICO 450	PICO 450M 
Heavy duty motor	•	Standard
Rear safety cover	•	•
Front and rear safety covers	•	n/a
Double slice thickness	•	n/a
Special colour	•	•
Special blades	•	Standard teflon
Jacfix	•	•

ACCESSORY	PICO 450	PICO 450M 
Wheeled base	•	•

*STANDAARDKLEUREN



RAL 3013



RAL 9005



RAL 9006

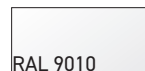

RAL 9010