

NEW

OPTIMA

Yatay kalıpcılar

- ✓ Hamura maksimum özen göstermek için yapay kalıplama
- ✓ Güçlü tempo
- ✓ Büyük üretim hacimleri
- ✓ Sessiz (-65 dB)
- ✓ Paslanmaz çelik



Saatte 1800 parçaya kadar

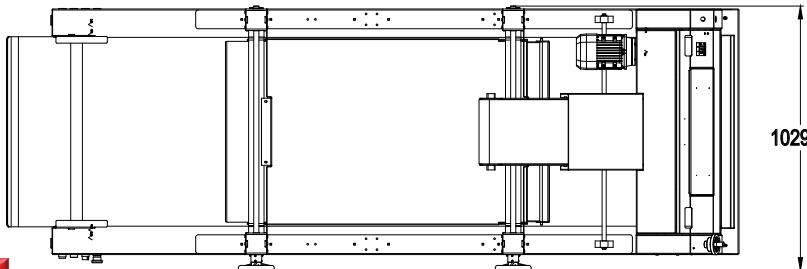
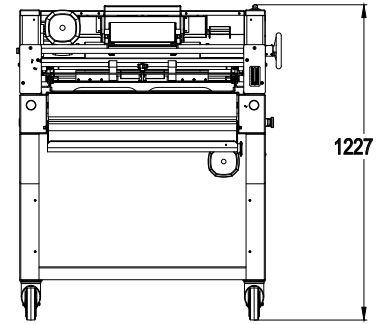
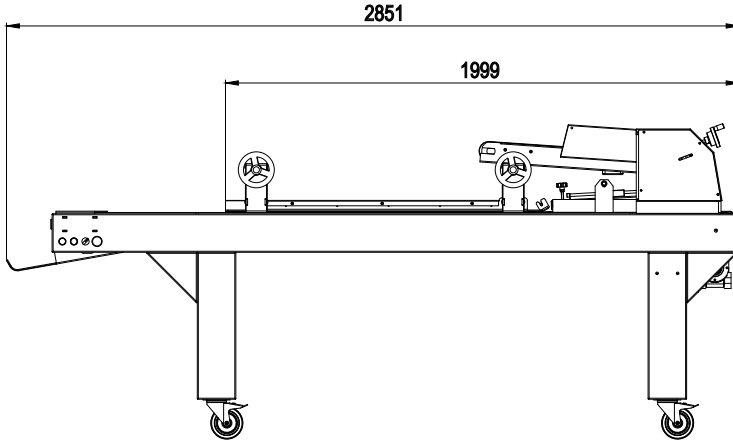



Bakımı kolay sıyrıcılar

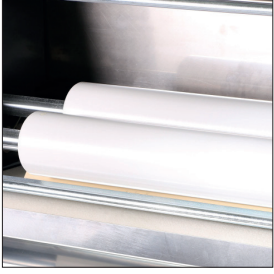

İki gıda sınıfı polietilen silindir



Ergonomik doğru göstergeler

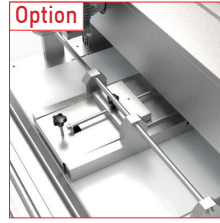

Option

Formmaster
Kalibratör

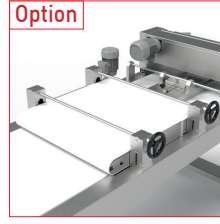

Option

Rollmaster
Motorlu
uzatma kayışı

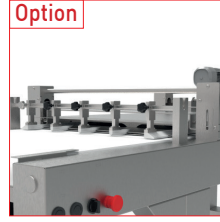

Option

Divimaster
4 küçük parça kesici
Yalnızca Formmaster ile
kullanılabilir ve
rula usta ile

OPTIMA

ÖZELLİKLER

Gram olarak hamur parçalarının min/max ağırlığı	50/1300
İki gıda sınıfı PETP haddeleme silindiri	•
Saatte parça olarak maksimum hız	1800
Güç kaynağı	400V üç fazlı
kW cinsinden motor gücü	0,8
Kemer tipi	Yüntop
kg cinsinden net ağırlık	310

SEÇİMLER

Sol / sağ kontroller	istek üzerine
----------------------	---------------

OPTIONS

Formmaster	•
Rollmaster	•
Divimaster	•
Besleme kayışı	•

ÖZELLİKLER

	OPTIMA + Formmaster	OPTIMA + Rollmaster	OPTIMA + Formmaster + Rollmaster	OPTIMA + Formmaster + Rollmaster + Divimaster
Gram olarak hamur parçalarının min/max ağırlığı	50/1300	50/1300	50/600	300/600
İki gıda sınıfı PETP haddeleme silindiri	•	•	•	•
Saatte parça olarak maksimum hız	1800	1200	1200	4800
kW cinsinden motor gücü	0,8	1	1 (2x0,37 + 0,18)	1 (2x0,37 + 0,18)
kg cinsinden net ağırlık	310	320	328	333