

PROLINE

- ✓ Esnek, çeşitli hamur türlerini işlemeyi mümkün kılar
- ✓ Yüksek hız
- ✓ Kompakt
- ✓ Ergonomik
- ✓ Tekneli un serpme tertibatı



Saatte 1800 parçaya kadar

*Bölücü ve kalıplayıcı dahil değildir.

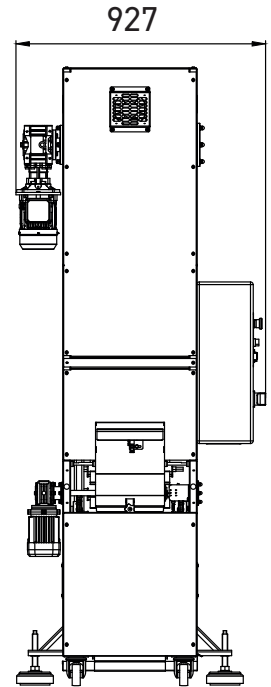
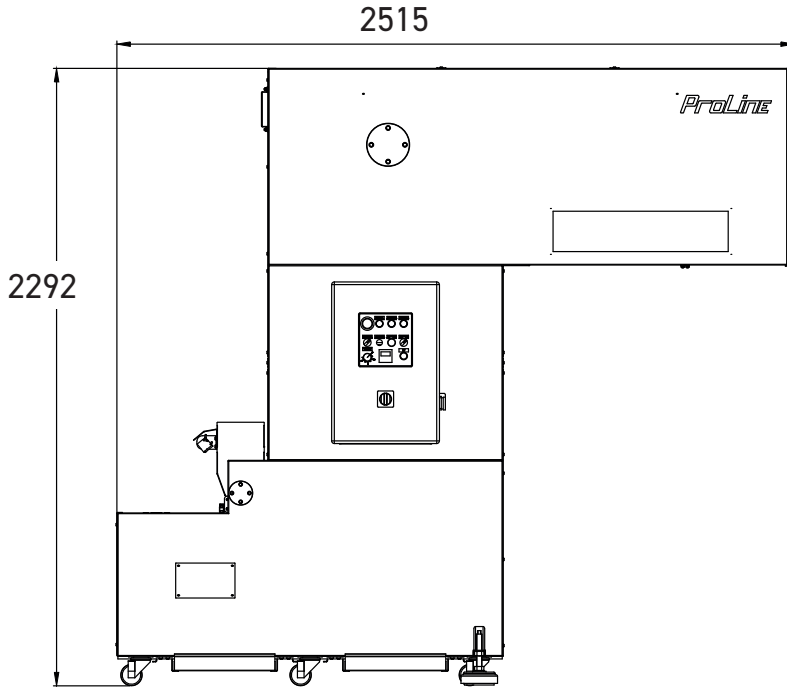



Tekneli unlama aparatı hamur parçalarının yapışmasını engeller.



Hava aspiratörü nemi tahliye eder.

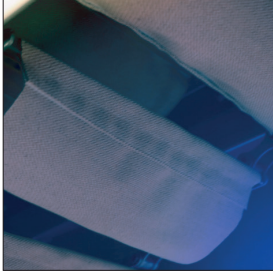

Antiseptik UV lambası prova alanını sterilize eder.

EK MODÜLLER



Hacimli bölücü



Yatay veya dikey kalıpcı



DRIVY-S Gevşeme Kemerı
MOOV-M
MOOV-L

ÖZELLİKLER

PROLINE

Ön uzama için gr cinsinden maksimum hamur parçaları ağırlığı	700
Ön yuvarlama için gr cinsinden maksimum hamur parçaları ağırlığı	550
Olukların cm cinsinden uzunluğu	30
Olukların cm cinsinden genişliği	13
Oluk sayısı	96
Kullanılabilir oluk sayısı	65
Korunmalı ve hava tahliyelı antiseptik UV lambası	•
Tekneli unlama cihazı	•

SEÇENEKLER

Güç kaynağı	230V three-phase 400V three-phase
Çıkış tipi	Left Right

SEÇENEKLER

Sol / sağ dışarı besleme kayışı	•
---------------------------------	---

HIZ (SAATLİK ADET)

Dakikada prova süresi	960	1200	1400	1800
	5:00	3:15	3:00	2:00



350 g baguette



Traditional
350 g baguette



Traditional
baguette 350 g
pointed ends



Soft white bread
500 g



550 g loaf



Traditional
550 g loaf



Rye loaf
550 g

KONFIGÜRASYON ÖRNEKLERİ

PROLINE + GDS + UNIC + MOOV-M

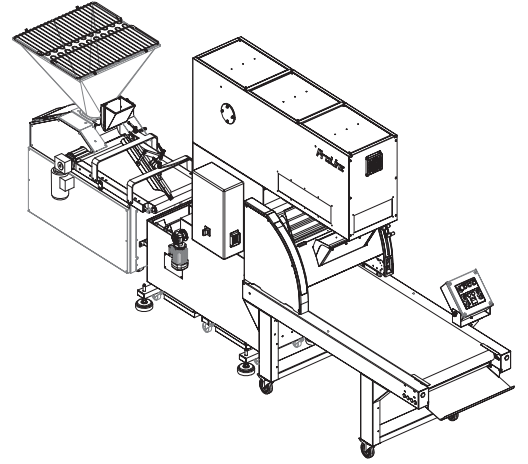
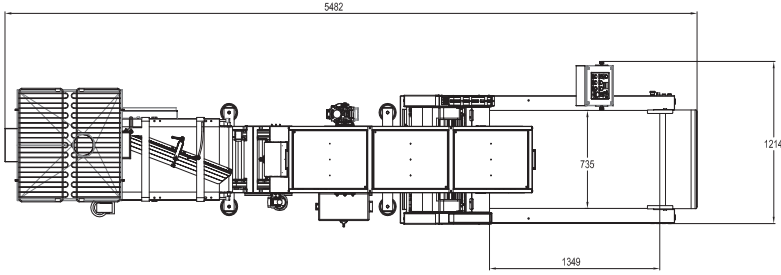

PROLINE + PE50P + HF +MOOV-M

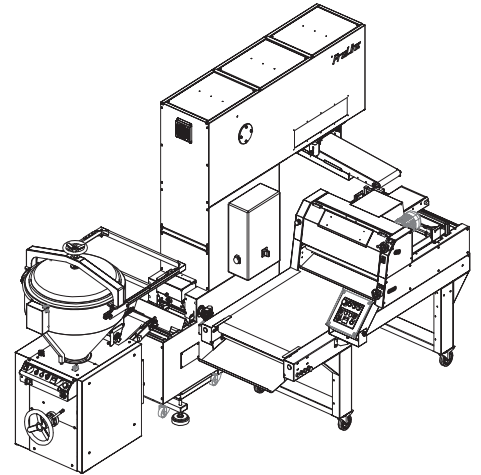
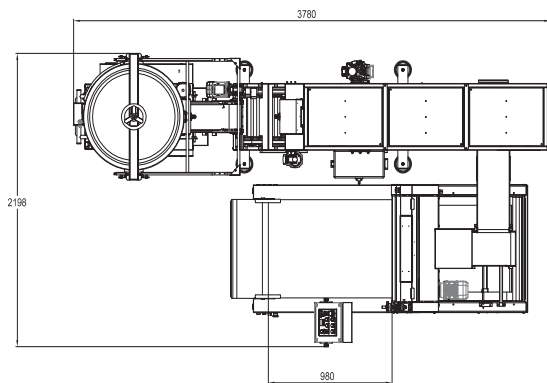

PROLINE + PE50P + UNIC + MOOV-M

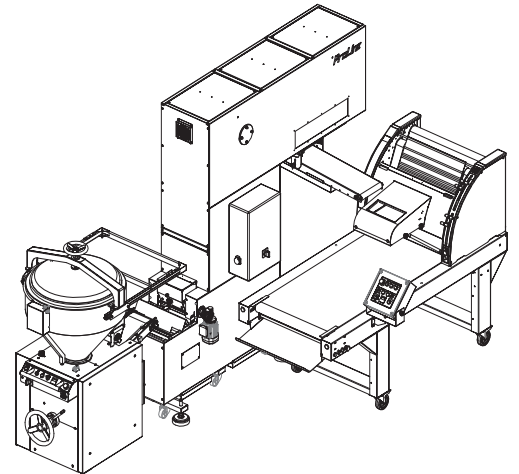
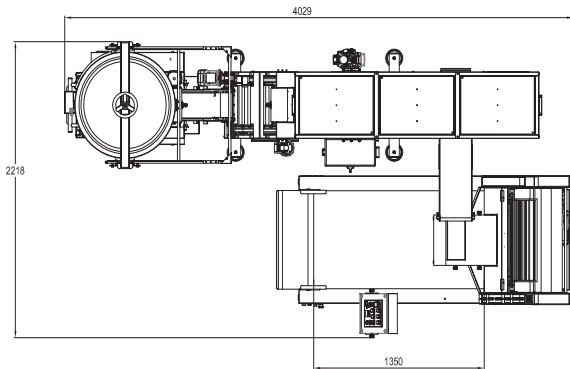

PROLINE + GDS + OPTIMA

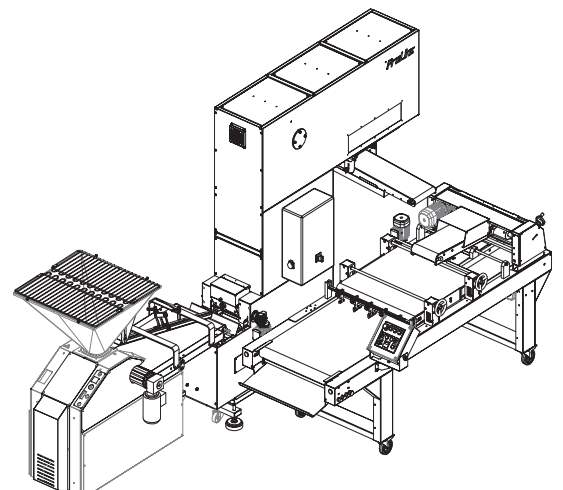
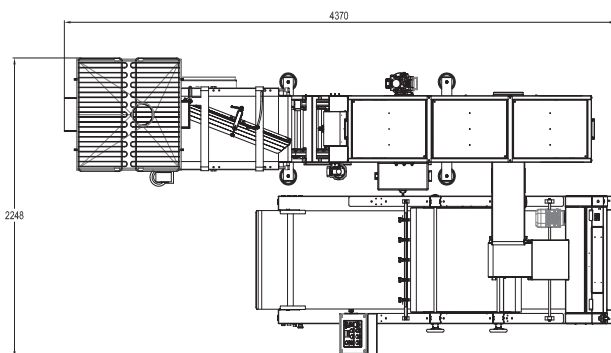

PRO+VE PROLINE AŐAĐIDAKİ ÜRÜNLERLE UYUMLUDUR

PE50P



GD



GDS



UNIC

TRADI

FORMA



HF



MOOV



MOOV

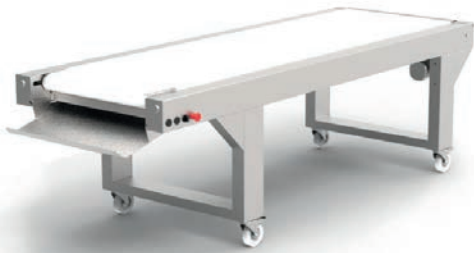

OPTIMA



**SATIŐ PERSONELİMİZ VE
TEKNİSYENLERİMİZ, MONTAJINIZ İÇİN
EKİPMAN SEÇENEKLERİ VE SEÇENEKLERDE
SİZE TAVSİYE ETMEK İÇİN HAZIRDIR.
LÜTFEN BİZİMLE İLETİŐİME GEÇİN.**

